

DOMINATOR
SERIES

Domestic Hot Water Heaters & Boilers



RBI

DOMINATOR SERIES



The Dominator™ Series from RBI offers superior performance and serviceability in a high efficiency, multi-stage boiler. At the heart of the unit is a sealed combustion chamber that provides the flexibility of using outside air or mechanical room air for combustion. The chamber design, with fan-assist, multi-speed blowers and state-of-the-art staging control, offers high efficiency staged firing in a compact package and virtually eliminates heat loss. The Dominator incorporates all the latest technological advances that engineers, contractors, and building owners look for when specifying boilers and water heaters.

Standard Equipment

- Finned copper tube heat exchanger, ASME 160# max WP, 2 pass
- Mounted & wired flow switch
- FM compliant gas train
- Sealed combustion chamber
- Mounted ASME relief valve (50# Boilers, 125# Water Heaters)
- Pump delay control
- Factory fired tested
- Barometric damper on Cat. 1 applications

Dependable, Efficient Performance

- 85.1% efficient
- Low NOx SCAQMD Rule 1146.2 certified
- Uginox alloy stainless steel burners
- Bronze headers – water heaters
- Cast iron headers – boilers
- 2 or 4-Stage firing modes
- Category I & III venting

Easy to Install and Service

- Slide-out heat exchanger
- Side intake, all sizes
- Rear intake, sizes 750-2100
- Stackable frame (seismic approval up to Zone 4)
- Field reversible headers
- Low voltage controls
- Direct vent up to 35' equivalent

Optional Features

- Cupro-nickel finned tubes
- Outdoor installation
- Stainless steel jacket
- Freeze protection package
- Thru-wall venting
- CSD-1 Compliant Gas Train & Controls



Unlike other manufacturers, which rely solely on achieving high operating efficiency, the Dominator Series is designed for total efficiency – based on operating efficiency, reliability and ease of service.

Dominator Series boilers and water heaters are also available with appealing, corrosion-resistant, brushed stainless steel jacket. Ideal for outdoor and indoor installation in corrosive or harsh environments such as coastal areas and processing applications requiring wash down.





THE SMART SPEC FOR ENGINEERS SERVICE-FRIENDLY ENERGY-SAVING SELECT

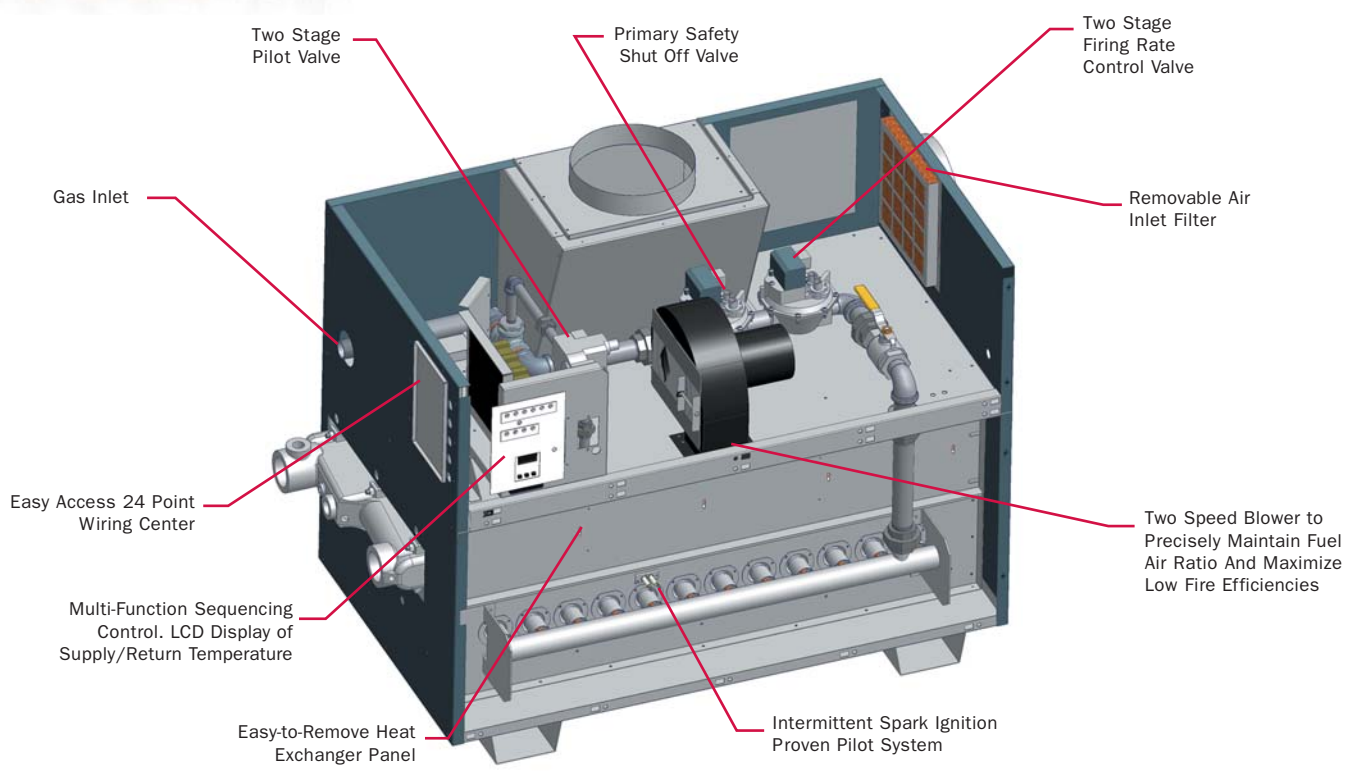

Load Matching Staged Firing

Unlike most atmospheric units that are limited to only two-stage firing, the Dominator provides up to four stages of firing, allowing the boiler/water heater to more closely match the heating load. The Dominator utilizes the most advanced Proportional Integral Derivative (P.I.D.) sequencing control on the market to better control the staging of the units. The control has six modes of operation that can be field set, with built-in standard features that are options on most competitive units. These standard features include outdoor reset and pump delay on temperature differential between the supply and return temperatures of the unit.

Proven Pilot Ignition System

The unique pilot ignition is safer and more reliable than the hot surface systems commonly used on other manufacturers' equipment. The system employs a burner tube as a pilot. Gas is injected into a single burner and ignited by spark. A flame rod then monitors the pilot tube flame. Once the pilot is proven the main gas valves are powered and the remaining burner tubes are safely lit. This proven system offers greater dependability and is superior to fragile HSI systems that can require frequent replacement.

EERS...

ENDLY CHOICE OF CONTRACTORS...

ION OF BUILDING OWNERS.



“Smart Service” Design

Ease of installation and service are trademarks of all RBI water heaters and boilers. Critical components are fully accessible to make short work of service and maintenance calls. The Dominator is the only sealed combustion chamber boiler/water heater with time-saving service features including a slide-out control cabinet for easy access to wiring and a slide-out heat exchanger for less time-consuming service and repair. And the Dominator is only 29.5" wide to fit easily through standard doorways.

Quality Construction for Dependable Performance

The Dominator features a robust, compact design using the best materials for more dependable performance. Quality components include stainless steel burner tubes and solid bronze headers on water heaters. The Dominator's design requires fewer blowers and gas valves to achieve staged firing. Fewer components mean reduced complexity, easier maintenance and service, and reduced likelihood of breakdown.

RBI Products are the easiest to service and maintain.

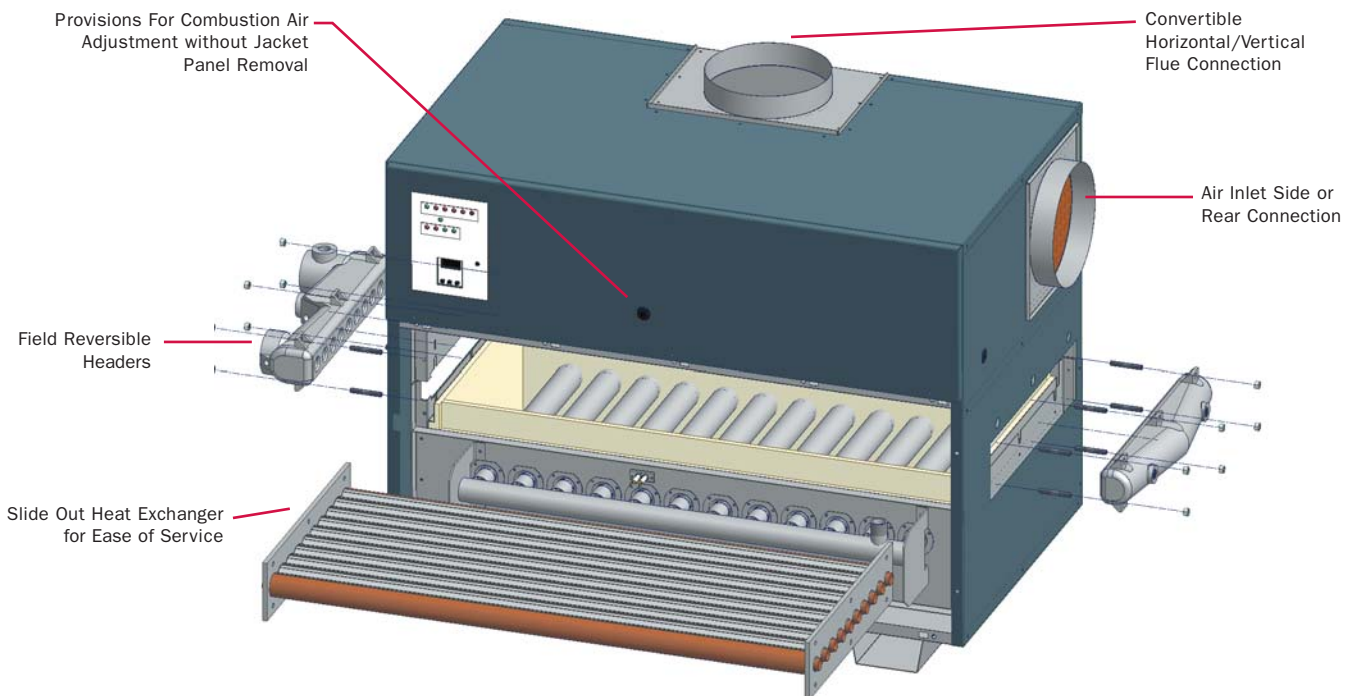

Rack and Stack

The Dominator offers greater flexibility and ease of installation in a space-saving design that leaves more elbowroom in the mechanical room. A rugged frame and stackable design allow you to install two units in the space of one small footprint.

Wide Variety of Venting Options

The Dominator provides added flexibility and ease of installation with multiple venting options and configurations. The sealed combustion chamber minimizes heat loss and requires less clearance from combustible walls.

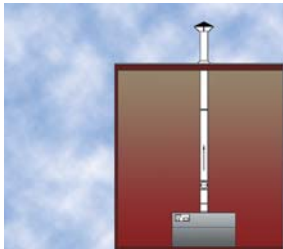

Conventional

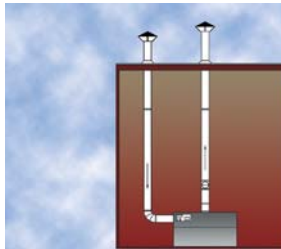

Outside Air – Vertical

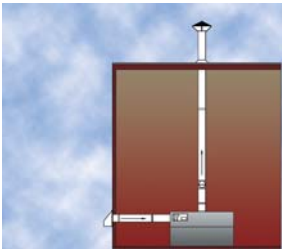

Outside Air – Horizontal/Vertical

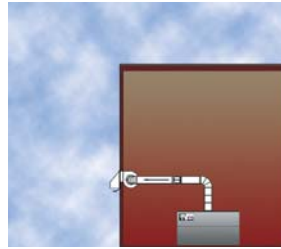

Side Wall

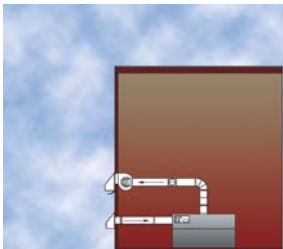

Outside Air – Horizontal

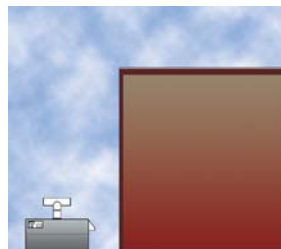

Outdoor



MODEL	DIM. "A"
300	22 1/8
400	28 5/8
600	35 1/8
750	41 5/8
900	48 1/8
1050	58 3/8
1350	71 3/8
1500	77 7/8
1950	97 3/8
2100	103 7/8

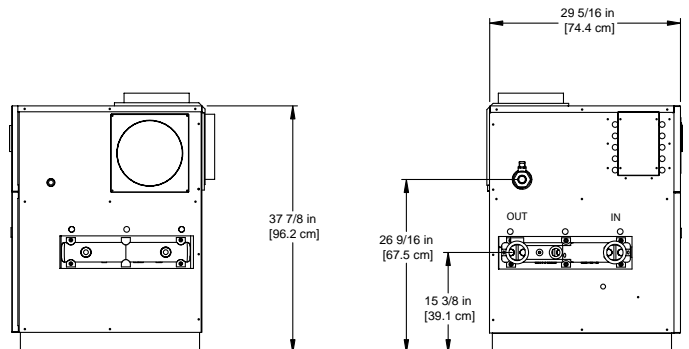
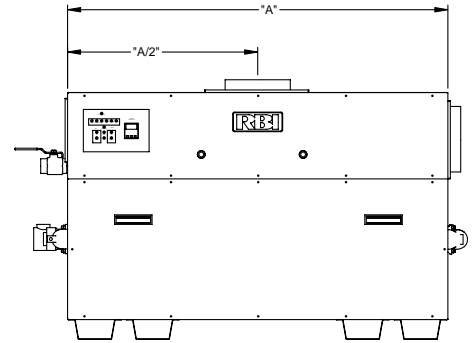

NOTE: Dimensions are approximate and should not be used to "rough-in" equipment.



2 1/2" Water Connections

HOURLY RECOVERY CAPACITY ΔT (GPH & LPH)

Model	40° F	22° C	60° F	33° C	80° F	44° C	100° F	56° C	120° F	67° C	140° F	78° C
300	766	2900	511	1934	383	1450	306	1160	255	967	219	829
400	1019	3858	679	2572	510	1929	408	1543	340	1286	291	1102
600	1532	5801	1022	3867	766	2900	613	2320	511	1934	438	1657
750	1916	7251	1277	4834	958	3626	766	2900	639	2417	547	2072
900	2299	8701	1532	5801	1149	4351	919	3480	766	2900	657	2486
1050	2682	10151	1788	6768	1341	5076	1073	4061	894	3384	766	2900
1350	3448	13052	2299	8701	1724	6526	1379	5221	1149	4351	985	3729
1500	3831	14502	2554	9668	1916	7251	1532	5801	1277	4834	1095	4143
1950	4980	18853	3320	12568	2490	9426	1992	7541	1660	6284	1423	5386
2100	5363	20303	3576	13535	2682	10151	2145	8121	1788	6768	1532	5801

TEMPERATURE RISE/PRESSURE DROP

Model	15° F / 8.3° C				20° F / 11.1° C				25° F / 13.9° C				30° F / 16.7° C				35° F / 19.4° C			
	Flow Rate		Pressure Drop		Flow Rate		Pressure Drop		Flow Rate		Pressure Drop		Flow Rate		Pressure Drop		Flow Rate		Pressure Drop	
	GPM	Ft	L/s	kPa	GPM	Ft	L/s	kPa	GPM	Ft	L/s	kPa	GPM	Ft	L/s	kPa	GPM	Ft	L/s	kPa
300	34.0	0.22	2.1	0.6	25.5*	0.13	1.6	0.4	20.4*	0.09	1.3	0.3	-	-	-	-	-	-	-	-
400	45.4	0.49	2.9	1.5	34.0	0.29	2.1	0.9	27.2*	0.19	1.7	0.6	-	-	-	-	-	-	-	-
600	68.1	1.30	4.3	3.8	51.1	0.76	3.2	2.3	40.8	0.51	2.6	1.5	34.0	0.36	2.1	1.1	-	-	-	-
750	85.1	2.35	5.4	6.9	63.8	1.38	4.0	4.1	51.0	0.91	3.2	2.7	42.6	0.65	2.7	1.9	36.5	0.49	2.3	1.4
900	102.1	3.84	6.4	11.3	76.6	2.25	4.8	6.6	61.3	1.49	3.9	4.4	51.1	1.06	3.2	3.1	43.8	0.80	2.8	2.4
1050	119.1*	6.23	7.5	18.4	89.4	3.66	5.6	10.8	71.5	2.42	4.5	7.1	59.6	1.73	3.8	5.1	51.1	1.30	3.2	3.8
1350	-	-	-	-	114.9*	7.17	7.2	21.1	91.9	4.74	5.8	14.0	76.6	3.38	4.8	10.0	65.6	2.54	4.1	7.5
1500	-	-	-	-	-	-	-	-	102.1	6.31	6.4	18.6	85.1	4.50	5.4	13.3	72.9	3.38	4.6	10.0
1950	-	-	-	-	-	-	-	-	-	-	-	-	110.6*	9.20	7.0	27.1	94.8	6.91	6.0	20.4
2100	-	-	-	-	-	-	-	-	-	-	-	-	119.1*	11.27	7.5	33.2	102.1	8.47	6.4	25.0

*Flow exceeds recommended maximum use a greater temperature rise or consult manufacturer. Cupro-Nickel heat exchanger should be considered.

DIMENSIONS & RATINGS

Model	Input		Output		Overall Length		Flue Vent Dia.		Ducted Air Size		Shipping Wt.
	MBH	kW	MBH	kW	In.	mm	In.	mm	In.	mm	
300	300	88	255	75	22 1/8	562	6	152	6	152	325
400	399	117	339	99	28 5/8	727	6	152	6	152	430
600	600	176	511	150	35 1/8	892	7	178	8	203	580
750	750	220	638	187	41 5/8	1057	8	203	8	203	725
900	900	264	766	225	48 1/8	1222	10	254	10	254	805
1050	1050	308	894	262	58 3/8	1483	10	254	10	254	875
1350	1350	396	1149	337	71 3/8	1813	12	305	12	305	1110
1500	1500	440	1277	374	77 7/8	1978	14*	356	12	305	1130
1950	1950	572	1659	487	97 3/8	2473	14*	356	12	305	1375
2100	2100	616	1787	524	103 7/8	2638	14*	356	12	305	1435

* 14" oval to round transition piece.

NOTE: The Dominator is a Category I or Category III appliance and must be vented into a negative pressure vent system.

In the interest of product improvement, RBI reserves the right to make changes without notice.



7555 Tranmere Dr., Mississauga, Ontario L5S 1L4
Tel. (905) 670-5888 Fax (905) 670-5782

260 North Elm Street, Westfield, MA 01085
Tel. (413) 568-9571 Fax (413) 568-9613

A MESTEK COMPANY www.rbiwaterheaters.com